

# Special Circuits Maintenance

## *Standard*

# Service Agreement

---

University Of Michigan  
Information Technology

July 1, 2004

---

- **1.0 Overview**
  - **2.0 Purpose**
  - **3.0 Funding of Services**
  - **4.0 Terms of Agreement**
  - **5.0 IT Communications Services Responsibilities**
  - **6.0 Unit Responsibilities**
  - **7.0 Performance Measures**
  - **8.0 Problem Resolution**
  - **9.0 Upgrades**
  - **10.0 Security**
  - **11.0 Accountability**
  - **Appendix A - Rates**
  - **Appendix B - Responsibilities Diagram**
  - **Appendix C - Account Information**
- 

### ***1.0 Overview***

This Service Agreement (SA) is between IT Communications (ITCOM) and a Unit on the Ann Arbor Campus. Under this SA, ITCOM agrees to provide Transport Facilities (Transmission Media) Maintenance at the service rates and duration specified. Specifically, this service covers copper plant wiring used for Networking connection, as well as, fiber optics distribution that currently exists within the Unit buildings for the following termed services; T1's, Point to Point circuits, ISDN-PRI circuits, HDSL circuits etc.

This SA also covers performance, reliability and other topics pertinent to maintenance, in particular it lists the key responsibilities of ITCOM and the Units.

---

## **2.0 Purpose**

The purpose of this SA is to establish a cooperative partnership between Units and IT by clarifying roles, setting rates and expectations, and providing mechanisms for resolving problems.

---

## **3.0 Funding Of Services**

Service rates are detailed in Appendix A and will be reviewed annually. Any revisions will be made by ITCOM, in consultation with the UM Connectivity Committee, prior to SA renewal.

---

## **4.0 Terms Of Agreement**

This SA contract becomes effective from the date of signing until the agreed expiration date. At the end of this term, it may be renewed by agreement of both the Unit and IT.

Except as provided for in the following paragraph, any changes or modifications to this SA must be submitted in writing to the signers of the Service Order 90 days in advance of the proposed implementation, and must be agreed to, in writing, by them. When this happens, an addendum will be attached to the SA.

---

## **5.0 IT Communications Services Responsibilities**

IT Communications Services Shall:

- 5.1 Comply with service standards as described in the “Service Delivery Standards.”
- 5.2 Provide the services and maintain the equipment covered by this agreement per the ITCOM “list of supported products”. ITCOM will retain spares for all supported products within this agreement.
- 5.3 Maintain physical records of fiber and/or copper termination ports and jack locations.
- 5.4 Provide and maintain the necessary materials and passive components for the continuous operation of the facilities.
- 5.5 Provide support necessary to repair and maintain the Special Circuits covered by this agreement.

- 5.6 Provide operational support for the following procedures:
    - Changing operational state of the Special Circuits
    - Maintenance / Repair service
  - 5.7 Provide the Unit Administrator, via email, 48 hours notice of scheduled, non-emergency outages due to maintenance. These are typically scheduled on Tuesday, Friday and Sunday mornings between 5 :00A.M and 8:00A.M.
  - 5.8 Provide notification via email to the Project Manager's or FLN whenever outside or other University service providers service issues are suspected.
  - 5.9 Provide a 24 x 365 method for Unit Administrator to determine and report a problem with their Special Circuits. **Units will be able to report problems per section 8.0.**
- 

## **6.0 Unit Responsibilities**

Customers Shall:

- 6.1 Submit a Service Order to ITCOM with an authorized signature. Provide the name of the person who will be the contact for ongoing maintenance.
- 6.2 Maintain their Special Circuits such that it does not compromise the performance or integrity of the Transport Facilities.
- 6.3 Prior to referring trouble to ITCOM, the Unit must perform first level diagnostics on the network electronics (i.e. hubs, routers, transceivers and switches), to confirm a circuit problem.
- 6.4 Provide support to the users of this service. Including, but not limited to the following:
  - First level Special Circuit support for service users
  - Distribution of software specific to use the Special Circuits
  - Assistance with installation of user network adapters
  - Distribution of applicable documentation for this service
  - Documentation covering Security and the proper use of this service
- 6.5 In consultation with others, as necessary, handle violations of Proper Use Policy, violations of system security and all other applicable policies, by service users.
- 6.6 Notify ITCOM of any change in Unit Administrator at least one week before the change occurs, and include the name of the temporary Unit Administrator. The Unit will tell ITCOM who the new, permanent Unit Administrator is not later than one week after the new person is hired via the service Order form, and/or direct communications to the ITCOM assigned Project manager for the specified Unit.

6.7 Provide ITCOM with the email, pager and phone contact information for the Unit Administrator. One of these methods must be designated by the Unit as the one that will be responded to 24 x 365. Any changes to these contact/notification methods must be communicated to ITCOM via the service Order form, and/or direct communications to the ITCOM assigned Project manager for the specified Unit.

6.8 Give ITCOM at least two (2) hours advance notice of a change in the Special Circuit that could potentially change the state of connectivity of the equipment covered in this contract. If the Unit Administrator is not sure if there will be an impact, then, he/she will contact the ITCOM for advice. Notice must be given either by calling 647-8888, or sending email to TROUBLE@UMICH.EDU. The Unit will be responsible for any charges which are caused by the Units failure to notify ITCOM.

6.9 Supply ITCOM with business hour and non-business hour contacts.

---

## 7.0 *Performance Measures*

### 7.1 Network Technical Performance

ITCOM will ensure the Special Circuit(s) is/are able to operate at the benchmark specifications.

If a Unit's Special Circuit compromises the performance of IT's Network, IT will take appropriate action to restore performance (if possible), or take other action, up to and including disconnecting service to the Special Circuit, if necessary, to maintain the Transport Facilities.

### 7.2 Network Maintenance Performance

IT Communications Services will:

#### 7.2.1 **Normal Business Hours -**

Provide the following service in the event that an outage or degradation occurs on the entire network or a large portion of the network, (this is dependent upon a number of factors including the number of attached users and the resources being accessed), **during normal business hours**, (i.e., Monday through Friday, 8:00 AM to 5:00 PM, excluding University Holidays):

(a) Priority maintenance/repair service, characterized by:

- a verbal response within 30 minutes of the ITCOM notification or the Unit's call, to provide information to the Unit on specific steps that have been/will be taken to resolve the problem, (i.e. refer to outside service providers within 24 hours if and when necessary)

- an on-site visit, if necessary, within two (2) hours of the verbal response (i.e., the maximum on-site response time will be two and a half (2 1/2) hours)

**\*note:** quicker response time can be negotiated into this SA modifying it to a Custom SA.

(b) If a customer request is received before 12:00pm for assistance at home, (ISDN CISCO products only), ITCOM will dispatch a technician the same day.  
If a customer request is received after 12:00pm for assistance from home, (ISDN CISCO products only), the ITCOM will dispatch a technician the next day.

(c) Provide communication daily with Customer to inform them of status, whenever there is a status change.

(d) Provide all time and materials required to restore service.

### 7.2.2 **Non-Business Hours -**

Provide the following service in the event that an outage or degradation occurs on the entire network or a large portion of the network, (this is dependent upon a number of factors including the number of attached users and the resources being accessed), **during non-business hours:**

(a) Priority maintenance/repair service, characterized by:

- a verbal response within 30 minutes of the ITCom notification or the Unit's call, to provide information to the Unit on specific steps that have been/will be taken to resolve the problem.

- an on-site visit, if necessary, within two (2) hours of the verbal response (i.e., the maximum on-site response time will be two and a half (2 1/2) hours).

(b) Provide materials only. Labor will be charged at the rates listed in Appendix A.

7.2.3 Provide service during normal business hours, and within eight (8) business hours, to repair a Special Circuit problem affecting one or more workstations.

### 7.3 User Perceptions of Network Performance

IT Communications Services and the Unit acknowledge that performance and performance measures are affected by many factors which may be difficult to define and/or anticipate due to the nature and uses of the underlying systems and clients. Further, we recognize that "perceived response time" by users is a critical performance measurement. Therefore, in cases where the "perceived response time" by users becomes an issue, problems will be resolved by the procedures outlined in Section 8.0, "Problem Resolution."

---

### **8.0 Problem Resolution**

To help determine the existence and scope of a possible problem, the Unit Administrator may call 647-8888, or send email to [TROUBLE@UMICH.EDU](mailto:TROUBLE@UMICH.EDU).

Similarly, IT Communications Services staff will contact the Unit Administrator by phone or pager to address any Transport Facilities problem being caused by the Unit's Special Circuit.

When performance measures do not meet the standards specified in this SA, the Unit and ITCom will jointly work to:

- Identify the cause of the problem.
- Resolve the problem as quickly as possible.

ITCom will own the problem until it is resolved or if the problem turns out not to be network related, the problem will be articulated to the Unit and transferred to the appropriate party.

If resolution is not achieved within 24 business hours, then the Unit and/or IT Communications Services may escalate the problem to the appropriate ITCom Project Manager (PM). If a resolution is not achieved within 72 hours, then the Unit and the Director of OM signers of the Service Order will be notified.

---

### ***9.0 Upgrades***

This agreement *does not* cover any upgrades that may be required to the Unit's Facilities.

---

### ***10.0 Security***

IT will take appropriate steps to provide physically secure access to the Unit's Transport Facilities.

---

### ***11.0 Accountability***

IT warrants that all reasonable measures within its resources shall be taken to ensure the performance, availability, and integrity of the Special Circuits covered in this agreement. IT assumes responsibility for the actions of IT staff and IT's liability for damages is limited to hardware replacement or repair, software fixes, and corrections to staff errors.

In cases of disasters due to the "Act of God", (i.e. lightning, electrical storm, tornado, hurricane, hail, ice, snow, sleet, earth movement, flooding, nuclear hazard), or University provided services that fail, ITCom is not financially responsible for replacement of components listed in this SA. ITCom will assist the Unit in replacement of components and restoral of services per the Time and Material SA. In addition, ITCom will assist the Unit with retribution through the University's Risk Management.

Units agree to maintain their Special Circuits such that they do not compromise the performance or integrity of IT's network infrastructure, nor violate security or other applicable policies. The Unit also agrees to have all service performed by ITCom Engineers and Technicians. If service is performed by others, the Unit agrees that IT will not be held liable for any problems that result, whether directly or indirectly. The Unit assumes responsibility for any misuse of the Special Circuits by users, will remedy such situations, and will be responsible for any expenses related to misuse by the Special Circuit users.

# APPENDIX A

## Special Circuit Service Rates

### Labor Rates:

The cost for this service is \$3.00 per day @ 365 days per year is \$1,095.00, billed at 12 equal monthly payments of \$91.25.

If a problem is found external to SA components and facilities which are not covered in this agreement, the Unit Administrators will be contacted to inform them of the extent of the problem. The Unit will be billed at the hourly rate (below) for the time spent in troubleshooting the reported problem

**Normal Business Hours**      **\$61.00 per hour**  
(Monday through Friday, 8:00A.M. to 5:00P.M. excluding University Holidays)

**Off Hours Support**              **\$61.00 per hour (There is a minimum labor charge of four (4) hours (\$244.00).**  
(Monday through Friday, 5:01P.M.to 7:59A.M., excluding University Holidays & Weekends)

# APPENDIX B

## Responsibilities

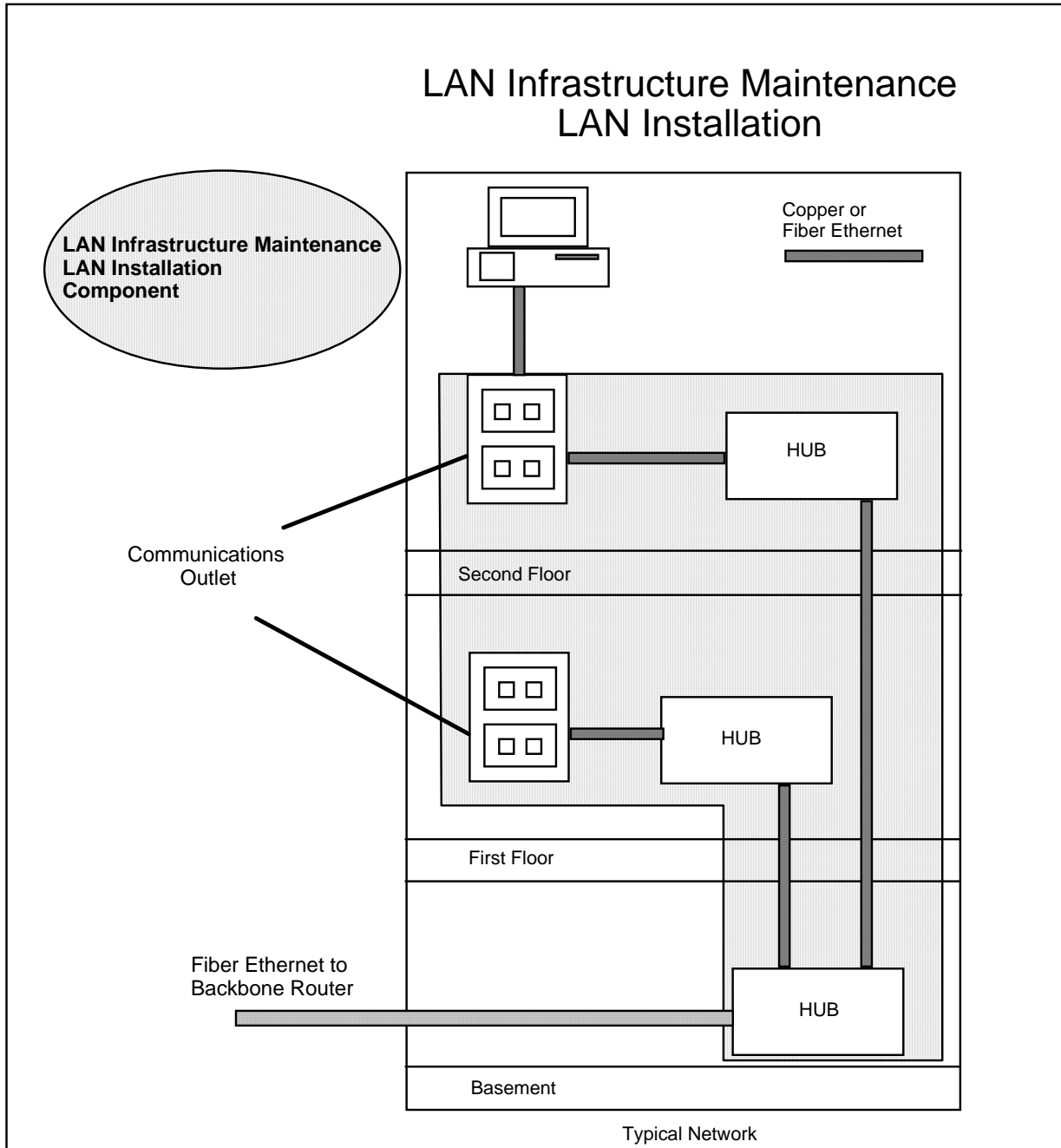

# APPENDIX C

## Special Circuit Service Agreement

DEPARTMENT: \_\_\_\_\_

NETNAME: \_\_\_\_\_

NETCODE: \_\_\_\_\_

YEARLY SA COST: \_\_\_\_\_

MONTHLY SA COST: \_\_\_\_\_

BILLING ID: \_\_\_\_\_

ITCOM SERVICE ORDER #: \_\_\_\_\_

BILLING TYPE/CODE: \_\_\_\_\_

BEGINNING DATE: \_\_\_\_\_

EXPIRATION DATE: \_\_\_\_\_

CHART FIELD NO. / SHORTCODE.: \_\_\_\_\_

AUTHORIZED SIGNATURE: \_\_\_\_\_

DATE SIGNED: \_\_\_\_\_

ITCom SA Manager: \_\_\_\_\_

Terms of Payment: Monthly \_\_\_\_\_

Local Area Network Location: \_\_\_\_\_

Router Port: \_\_\_\_\_

Contact Information: \_\_\_\_\_

Name  
Phone Number  
E-Mail  
Pager

\*\* After hours contact information:

\_\_\_\_\_  
\_\_\_\_\_  
\_\_\_\_\_  
\_\_\_\_\_